

No. 686,827.

Patented Nov. 19, 1901.

A. H. MUNSELL.
PHOTOMETER.

(Application filed Feb. 6, 1901.)

(No Model.)

2 Sheets—Sheet 1.

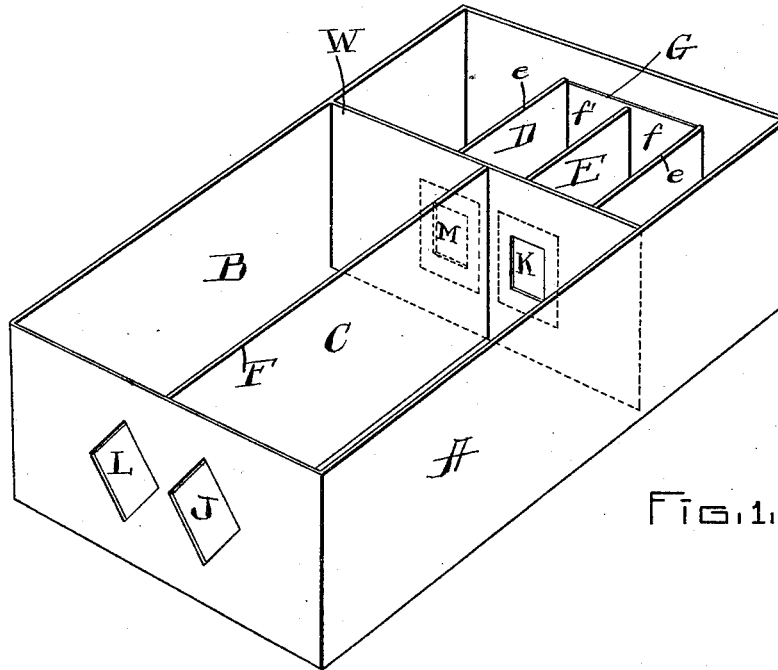

FIG. 1.

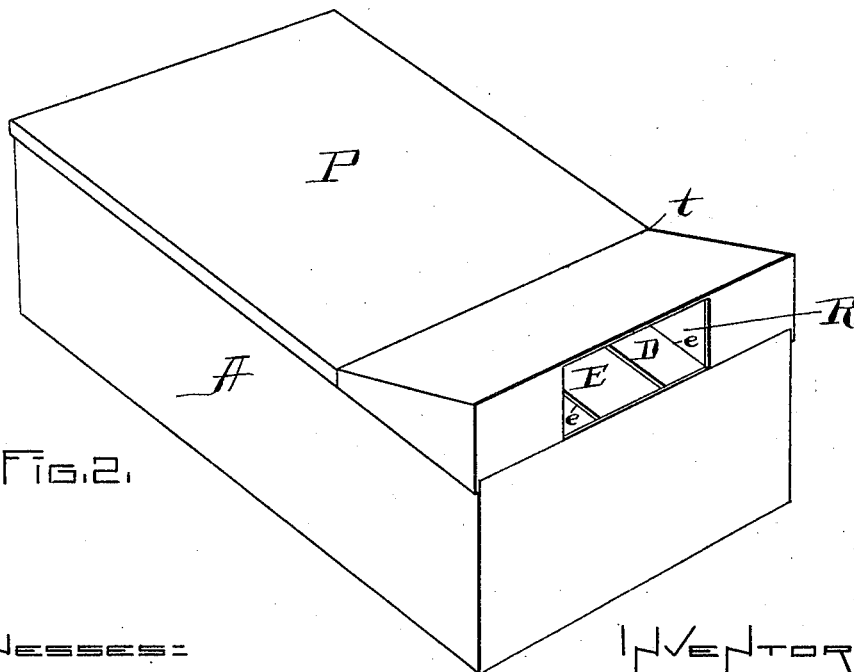

FIG. 2.

WITNESSES:

Everett W. Curtis
A. G. Sullivan.

INVENTOR:

Albert H. Munsell
by Chas. F. Perkins, Attorney

No. 686,827.

Patented Nov. 19, 1901.

A. H. MUNSELL.
PHOTOMETER.

(Application filed Feb. 6, 1901.)

(No Model.)

2 Sheets—Sheet 2.

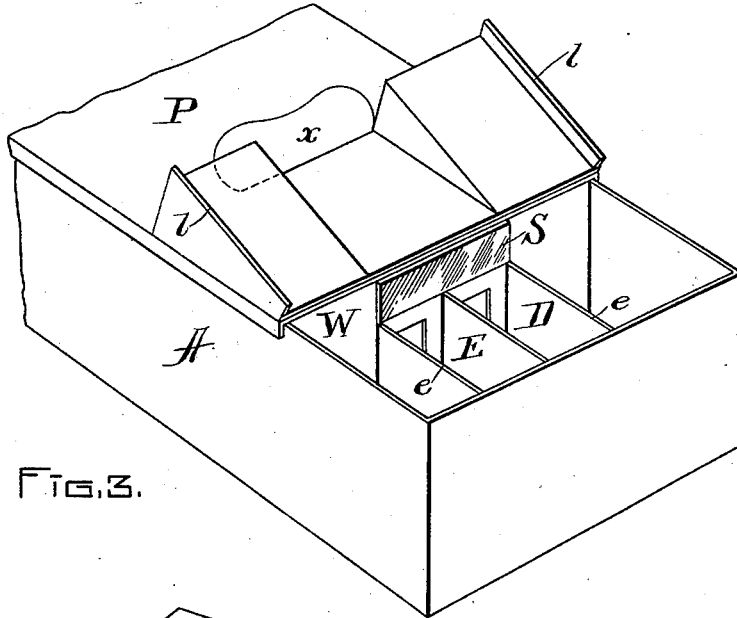

FIG. 3.

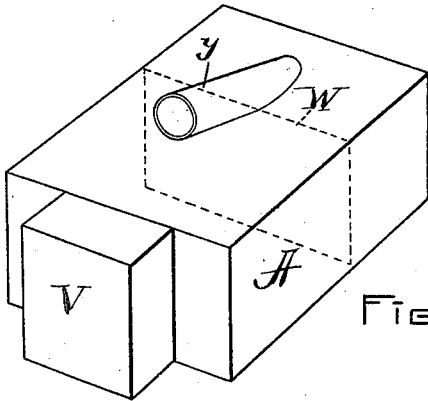

FIG. 4.

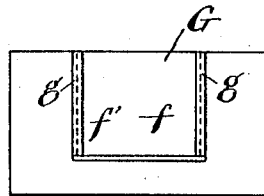

FIG. 5.

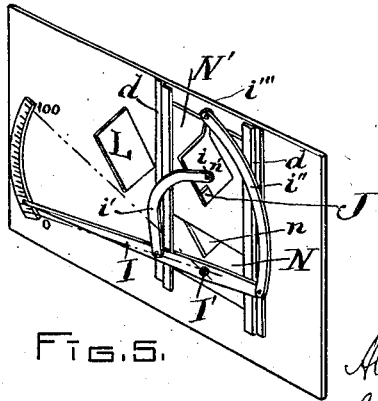

FIG. 6.

WITNESSES:

Ernest W. Curtis
A. G. Sullivan

INVENTOR:

Albert H. Munsell
by Chas. F. Perkins, Attorney

UNITED STATES PATENT OFFICE.

ALBERT H. MUNSELL, OF BROOKLINE, MASSACHUSETTS.

PHOTOMETER.

SPECIFICATION forming part of Letters Patent No. 686,827, dated November 19, 1901.

Application filed February 6, 1901. Serial No. 46,267. (No model.)

To all whom it may concern:

Be it known that I, ALBERT H. MUNSELL, a citizen of the United States, residing at Brookline, in the county of Norfolk, State of Massachusetts, have invented new and useful Improvements in Photometers, of which the following is a specification.

My invention consists of a device for measuring the luminosity of lights, colors, pigments, and other substances, which is simple in construction, inexpensive to make, easily used, and accurate in results.

In the accompanying drawings, illustrating my invention, Figure 1 is a perspective view of the box with the lid removed. Fig. 2 is a perspective view of the same with the lid attached and showing the rear end in elevation. Fig. 3 is the same view as Fig. 2 with the hood portion of the lid turned back. Fig. 4 is a perspective view of the box, showing a modification of the sight-opening and an auxiliary box containing an artificial light. Fig. 5 is an elevation of the front end of the box, and Fig. 6 is an elevation of the interior of the rear end of the box.

A is a rectangular box, which may be made of any size to suit the constructor. I have found by experience that a pocket size is practicable; but nicer measurements can be taken with a larger box, and I recommend for such purpose one that is at least twenty-two inches long, twelve inches wide, and ten inches deep. It is not essential that the box should be rectangular in form. It is a more convenient shape; but other forms may be employed. It should be made of wood, cardboard, or other opaque substance and lined with material that will reflect as little light as possible, for which purpose black velvet is especially adapted. The box is divided into four chambers B C D E by a longitudinal partition F, a transverse partition W, and two short partitions *ee*. The partition W and that portion of the partition F separating the chambers B C are the full height of the box. The short partitions *ee* and that portion of the partition F separating the chambers D E are of less height, allowing space for the mirror S between the top of the partitions and the lid of the box.

The color, pigment, or other substance to be measured is deposited upon a card, such

as G, which is inserted into and supported by grooved cleats or slides *g g*, secured to the rear end of the interior of the box. A slight space is left between the end of the partition F and the interior wall of the box to admit the card. The particular method shown of supporting and exposing the colors or substances to be measured is not an important feature of my invention. Any means of exposing the card so that its surface may be observed within the box and of protecting it from extraneous light is within the scope of my invention. One half of the card G has a white surface *f*, and the other half is occupied by the color or other substance *f'* to be measured. The object of the partition F is to prevent the beam of light which is directed upon one space from falling upon the other space in the slightest degree.

K is a rectangular aperture in the partition W, through which the beam of light is directed upon the white space *f* of the card G. J is preferably a square aperture in the front end of the box. These apertures J K are made to register in line with each other and with the white space *f* upon the card G, so that a direct beam of light from without the box will fall upon the white space *f*. The partition F confines the action of the beam of light entering the apertures J and K to the white space *f*.

L and M are apertures similar to J and K and are made in the front end of the box and in the partition W, respectively, for the purpose of directing a beam of light upon the colored space or other substance *f'* of the card G to be measured.

Different forms of apertures may be employed than those shown in the drawings. The forms shown are well adapted to the construction of the shutter herein described. I prefer to use ground glass in the apertures J and L, especially when the light is strong, in order to temper or modify its intensity in the box. Lenses and other media may be used in the apertures J and L.

As before stated, the two beams of light entering the apertures J and L are isolated from each other within the box, and each of the spaces *f f'* is illumined only by its respective beam of light.

It is not essential to a practical use of the

device nor to my invention to employ the partition W, but it is beneficial in excluding the dispersed or reflected light, which occurs in the chambers B and C; neither is it essential to employ the short partitions *ee*. Without the partition W and the partitions *ee* slight differences might occur in the conditions of the two beams as they fall upon the color-spaces. It is desirable that these conditions should be precisely the same and to the extent that they differ the results of the measurements would require correction.

A calibrated shutter is provided for the aperture J for the purpose of varying the size of the opening. The form of shutter selected for the purpose of illustrating my invention consists of two rectangular cards or strips N N', sliding upon the surfaces of each other, and in guideways *d d*, secured to the front end of the box. Each of the strips N N' of the shutter has an opening of the same size and shape as the aperture J and exactly registers with the latter when the shutter is wide open. Pivoted on a pin *i* in the strip N, near the top of its opening *n*, is the arm *i'*, which has its other end pivoted to the lever L, which is fulcrumed to the box at I'. The free end of the lever is tapered to a point to serve as an indicator upon the scale described upon the box, as shown in Fig. 5. The arm *i'* is pivoted upon a pin *i''* in the upper end of the strip N' and is pivoted at its other end to the lever L. When the shutter is wide open, the indicator will register "100" on the scale, which indicates maximum luminosity, and when entirely closed will register "0," which indicates absence of luminosity or total darkness. Partial opening of the shutter will give intermediate readings of the scale according to the extent of the opening. A small slot is formed at the top of the opening *n'* to admit the pin *i* when the shutter is wide open, so as to allow the edges of the openings *n n'* to exactly coincide with each other. By the use of the form of shutter described the aperture through which the light is admitted will always be square and centrally located whatever may be the degree of opening.

It is obvious that various forms of shutters can be employed for the purpose described and different arrangements devised for measuring the extent of the opening J, and I do not limit my invention to the particular constructions shown, as they are illustrations only of the principle upon which my device is operated.

P is the lid, which may be secured to the box in any suitable manner. The rear end of the lid is slightly inclined and is hinged at *t* for the purpose of being thrown back, as shown in Fig. 3. Triangular pieces *l*, secured to the lid, serve to support the rear end of the lid P at an incline and to exclude the light from the sight-opening R. The lid is slightly extended over the end of the box to form a hood X to assist in excluding the light

from the opening R. The opening R is provided for the purpose of observing the color-spaces *ff'* reflected in the mirror S, secured at a proper angle for the purpose. In the drawings the mirror S is shown as secured to the partition W; but it is evident that it may be supported by other means without affecting the substance of the invention. While I prefer to employ the arrangement of the opening R and the mirror S for observing the color-spaces, an opening may be made in the lid of the box, with a tubular projection T, as shown in Fig. 4, or a similar opening may be made in the side of the box for that purpose. It is immaterial at what point the sight-opening is made so long as the color-spaces can be readily observed without admitting other light than enters through the apertures J and L. The box could also be used without the lid in a darkened room by placing an artificial light in a tight auxiliary box V. (Shown in Fig. 4.) It is much more convenient, however, to use the closed box, in which case the daylight or any artificial light may be employed without a special arrangement therefor.

In the practice of my invention a card G, bearing a white space, as *f*, and a color-space, as *f'*, is inserted in the slides *gg* and exposed to the beams of light admitted through the apertures J and L. If the shutter is wide open, the operator looking through the opening R will observe that the white space is more luminous than the other and will gradually diminish its luminosity by adjusting the shutter until its luminosity is equal to that of the color-space. The reading of the scale will then determine precisely the degree of luminosity of the color or substance exposed.

My device is not only adapted for comparing the luminosity of a substance with a white surface, but it is equally adapted for comparing the same with any colored surface whose degree of luminosity has been predetermined. It is simply necessary to have a standard of comparison, and white has been selected in describing the invention because it possesses the maximum luminosity.

What I claim, and desire to secure by Letters Patent, is—

1. A photometer consisting of a box or cabinet having two apertures therein arranged to receive light from a common source, one of said apertures being provided with an adjustable shutter to vary the size thereof, a central partition located between said apertures to separate the beams of light entering therein, combined with a screen located in said box so as to receive the said beams of light side by side and suitable means whereby the said screen and the reflected light thereon may be observed.

2. A photometer consisting of a box or cabinet having two apertures in one wall thereof, one of said apertures being provided with an adjustable shutter to vary the size thereof, a

central partition located between said apertures to separate the beams of light entering therein, combined with a screen located in said box so as to receive the said beams of light side by side and an opening into said box so located that the said screen and the reflected light thereon may be observed from without the box.

3. A photometer consisting of a box or cabinet having two apertures in one wall thereof, one of said apertures being provided with a calibrated shutter to vary the size thereof, a central partition located between said apertures so as to completely isolate from each other the beams of light entering therein, combined with a screen located in said box so as to receive the said beams of light side by side and an opening into said box so located that the said screen and the reflected light thereon may be observed from without the box.

4. A photometer consisting of a closed box or cabinet having two apertures in one wall thereof, one of said apertures being provided with a calibrated shutter, a central partition located between said apertures and dividing the interior of the box into two closed and distinct compartments, combined with a screen located in said box so as to receive the beams of light side by side and an opening into said box so located that the said screen and the reflected light thereon may be observed from without the box.

5. A photometer consisting of a closed box or cabinet having two apertures in one wall thereof, a central partition located between said apertures and dividing the interior of the box into two closed and distinct compartments, combined with a calibrated shutter adapted to vary the size of one of said apertures, and a sight-opening in said box for the purpose of taking observations.

6. A photometer consisting of a box or cabinet having two apertures in one wall thereof, one of said apertures being provided with a calibrated shutter, a central partition located between said apertures, a transverse partition having two apertures therein registering with the apertures in the wall of the box, combined with a screen located in said box so as to receive the said beams of light side by side and an opening into said box so located that the said screen and the reflected light thereon may be observed from without the box.

7. A photometer consisting of a box or cabinet divided into four chambers, B, C, D, E, by the longitudinal partition, F, the transverse partition, W, and the partitions, e, e, one wall of the box having two apertures, J, L, opening into the chambers, C, B, respectively, and the partition, W, having two apertures therein, K, M, registering with the apertures, J, L, respectively, and one of said apertures, J, having a calibrated shutter combined therewith, said box having an opening through which the reflected light may be observed from without the box.

8. A photometer consisting of a box or cabinet divided into four chambers by the longitudinal partition, F, and the transverse partition, W, one wall of the box having two apertures, J, L, and the partition, W, having two apertures, K, M, registering with the apertures, J, L, respectively, combined with a screen displaying varied surfaces and exposed to the beams of light admitted through said apertures, a mirror, S, and a sight-opening, R, for observing said screen, substantially as described.

ALBERT H. MUNSELL.

Witnesses:

CHAS. F. PERKINS,
E. J. SMITH.